



CC30/50 Compression Load Cell

TECHNICAL SPECIFICATION



CC-30
White shield
2.13 mv/V



CC-30-3
Gray shield
3 mv/V



CC-50
Red shield
2.5 mv/V

The CC-30/50 is a heavy duty compression load cell, particularly well suited for higher capacity mobile applications. These all-weather load cells add a valuable scale function to mixers, wagons, boxes, tanks, etc.

FEATURES & BENEFITS

The CC-30/50 offers 0.1% accuracy, 30,000/50,000 Kg capacity, temperature compensation and interchangeability with many competitive models. The simple, compact design and rugged, sealed construction of the CC-30/50 assures long terms performance in all types of field installations.

OPTIONS

Polyurethane disk – 2-3/8" dia x 3/8" (2 per cell)

Cable length – 20 or 30 ft

Cable termination –

- 5-pin connector
- Tinned wire leads

Mounting options – Consult factory

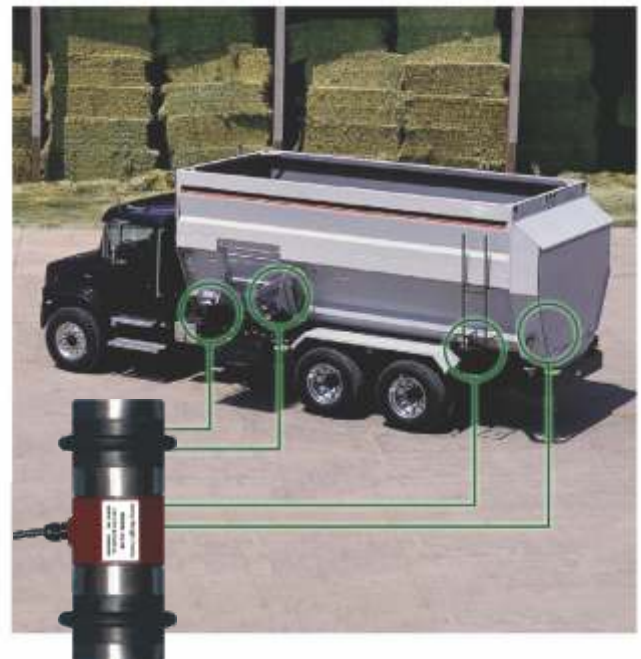

CC-30 and CC-50 load cells are typically used on larger capacity truck mounted applications. Simply place the load cells between the box and the frame. The load cells offer 0.1% accuracy, 30k or 50k capacity, temperature compensation and interchangeability with many competitive models.

CC30/50 Compression Load Cell

SPECIFICATIONS

Capacity: 30,000/50,000 Kg

Material: Alloy steel

Finish: Nickel plated

Accuracy: ±0.10 %

Full scale output:

CC-30: 2.13 or 3 mv/V

CC-50: 2.50 mv/V

Safe overloading rating: 150%

Maximum overload rating: 200%

Temp. compensation range: 0° to 125° F (-18° to 52° C)

Maximum excitation voltage: 20V AC or DC

Input resistance: 370 Ohms +10% -1%

Output resistance: 350 Ohms ±1%

Zero balance: 0 to +0.1 mv/V

Cable length: 20 or 30 ft

Shipping weight: 4.5 lb

Warranty: 3 years

5-pin connector color code:

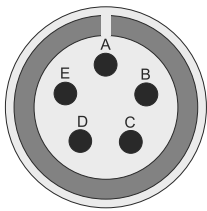

B	Green . . .	+Excitation
D	Black . . .	-Excitation
C	White . . .	+Signal
A	Red . . .	-Signal
E	Orange . . .	Shield

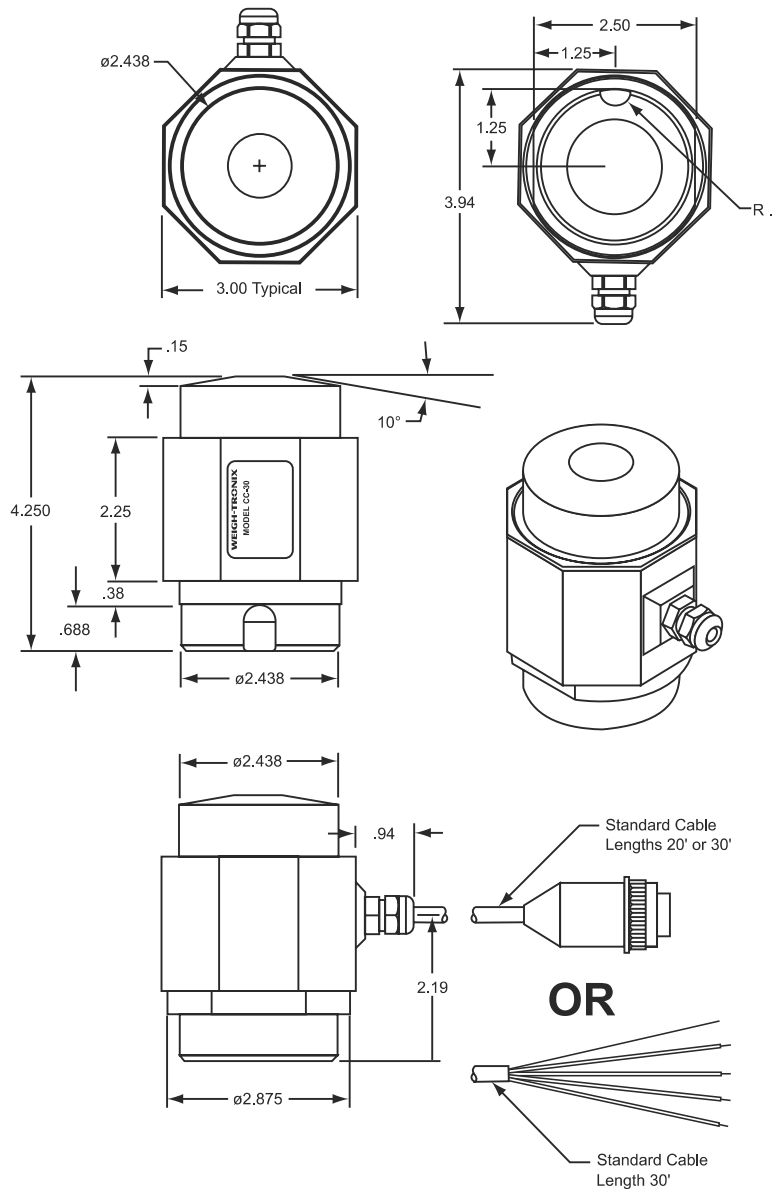

Avery Weigh-Tronix

Scales for Agribusiness

AVERY WEIGH-TRONIX

1000 Armstrong Drive,
Fairmont, MN 56031-1439 USA

Visit www.averyweigh-tronix.com or call us
Avery Weigh-Tronix distributor | Avery Scales (Private) Limited
Karachi, Lahore, Faisalabad, Multan, Hyderabad & Rawalpindi
Phones: 021-34825482-34825485-34825479, 042-36307115
& 041-8542120

Email: avery@cyber.net.pk | Ihravery@cyber.net.pk &
averyfsd@hotmail.com